

Centripetal Force Lab

- Purpose:** a) To experimentally determine the relationship between centripetal force and velocity for a cork moving in a circle.
b) To determine the approximate velocity that could be obtained with a centripetal force of 40 washers.

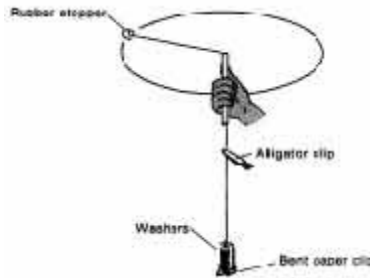

Centripetal force apparatus

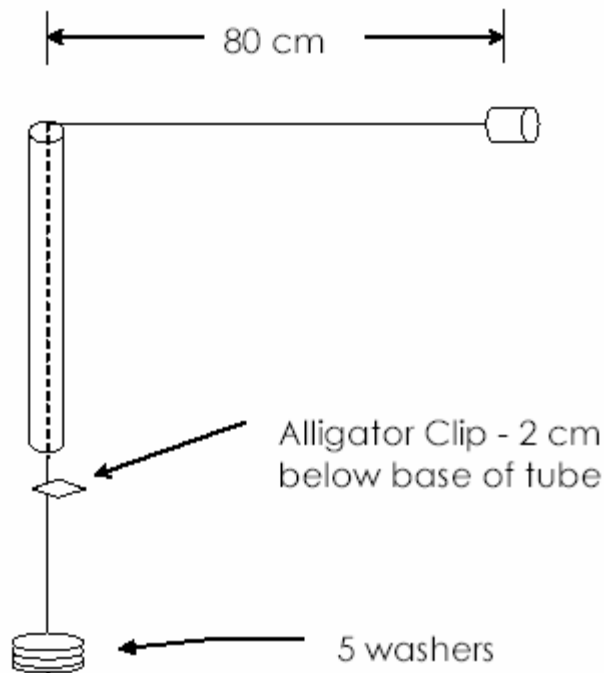

Page 2 of your lab - Try to come as close as possible to reproducing this drawing using the drawing tools in your word processor) (Do not use scanner) INCLUDE ALL LABELS AND THE TITLE ABOVE.

Calculations

Radius = 80 cm = .80 meters

Circumference = $2\pi r = 2(3.14) \times (.80 \text{ m}) = \underline{\hspace{2cm}}$

Velocity = Circumference/ Time for one revolution (show one example)

<i>Force</i> <i>(Number of Washers)</i>	<i>Time for 10 Revolutions</i> <i>(seconds)</i>	<i>Time for One Revolution</i> <i>(seconds)</i>	<i>Velocity</i> <i>(m/s)</i>	<i>Velocity</i> ² <i>(m/s)²</i>
0	0	0	0	0
5				
10				
15				
20				

Plotting and analyzing the data

Plot Force vs. Velocity then Force vs. Velocity squared on a second graph
(***** **Force** on **vertical** axis for both plots *****)



Tips for lab report

- ✓ **Introduction** - Briefly define and discuss centripetal force (F_c). Discuss the three factors that determine F_c . (See equation) Then mention which factor of the three your lab report is looking at.
- ✓ **Conclusion** – a) Describe the shapes of each plot and identify their mathematical relationships. b) Use the relationships you found to determine the velocity that would be obtained if your apparatus had 40 washers. Explain how you arrived at your answer.